

EQ Line

LITHION
BATTERY TECHNOLOGY



EQ LINE PRELIMINARY SPECIFICATIONS
PEDESTRIAN POWER PALLET TRUCK
24V, 1.6 TONNES

NPP1602L

A COST-SAVING WORKMATE

CARRY MORE – PAY LESS

This handy little warehouse assistant takes much of the effort and expense out of moving goods. Robustly built, easy to manoeuvre, and strong enough for loads up to 1.6 tonnes, it's a reliable aid to productivity. You can expect trouble-free performance and low running costs over a long lifetime.

CAT[®]

Characteristics			
1.1	Manufacturer		
1.2	Manufacturer's model designation		
1.3	Power source		
1.4	Operator type		
1.5	Load capacity	Q	(kg)
1.6	Load centre distance	c	(mm)
1.8	Load wheel axle to fork face (forks lowered)	x	(mm)
1.9	Wheelbase	y	(mm)
Weight			
2.1b	Truck weight without load, with maximum battery weight		kg
2.2	Axle loadings with nominal load & maximum battery weight, drive / load side		kg
2.3	Axle loadings without load & with maximum battery weight, drive / load side		kg
Wheels, Drive Train			
3.1	Tyres: PT=Power Thane, Vul=Vulkollan, P=Polyurethane, N=Nylon, R=Rubber drive/load side		
3.2	Tyre dimensions, drive side		(mm)
3.3	Tyre dimensions, load side		(mm)
3.4	Castor wheel dimensions (diameter x width)		(mm)
3.5	Number of wheels, load/drive side (x=driven)		
3.6	Track width (centre of tyres), drive side	b10	(mm)
3.7	Track width (centre of tyres), load side	b11	(mm)
Dimensions			
4.4	Lift height	h3	(mm)
4.9	Height of tiller arm / steering console (min./max.)	h14	(mm)
4.15	Fork height, fully lowered	h13	(mm)
4.19	Overall length	l1	(mm)
4.20	Length to fork face	l2	(mm)
4.21	Overall width	b1	(mm)
4.22	Fork dimensions (thickness, width, length)	s / e / l	(mm)
4.25	Outside width over forks (minimum-maximum)	b5	(mm)
4.32	Ground clearance at centre of wheelbase, (forks lowered)	m2	(mm)
4.34a	Working aisle width (Ast) with 800 x 1200 mm pallets, load lengthwise	Ast	(mm)
4.35	Turning radius	Wa	(mm)
Performance			
5.1	Travel speed, with/without load		km/h
5.2	Lifting speed, with/without load		m/s
5.3	Lowering speed, with/without load		m/s
5.8	Maximum gradeability with / without load		%
5.10	Service brake		
Electric motors			
6.1	Drive motor capacity (60 min. short duty)		kW
6.2	Lift motor output at 15% duty factor		kW
6.3	Battery to DIN		
6.4	Battery voltage/capacity at 5-hour discharge		V /Ah
6.5	Battery weight		kg
6.6a	Energy consumption according to EN16796		kWh / h
Miscellaneous			
8.1	Type of drive control		
10.7	Level of noise at the ear level of the driver according to EN 12 053:2001 and EN ISO 4871 in work LpAZ		dB(A)

Cat Lift Trucks
NPP16Q2L
Battery
Pedestrian
1600
600
966
1258
P/P
230x70
84x84 single
82x110 Tandem
100x40
1x+2/4
510
367 / 512
120
740 / 1190
85
1590
440
729
60/173/1150
540 / 685
25
2068
1422
5.7/6.0
0.025/0.035
0.035/0.030
10/20
Electromagnetic
1.3
0.8
no
24/100
34.5
0.187
AC
<70

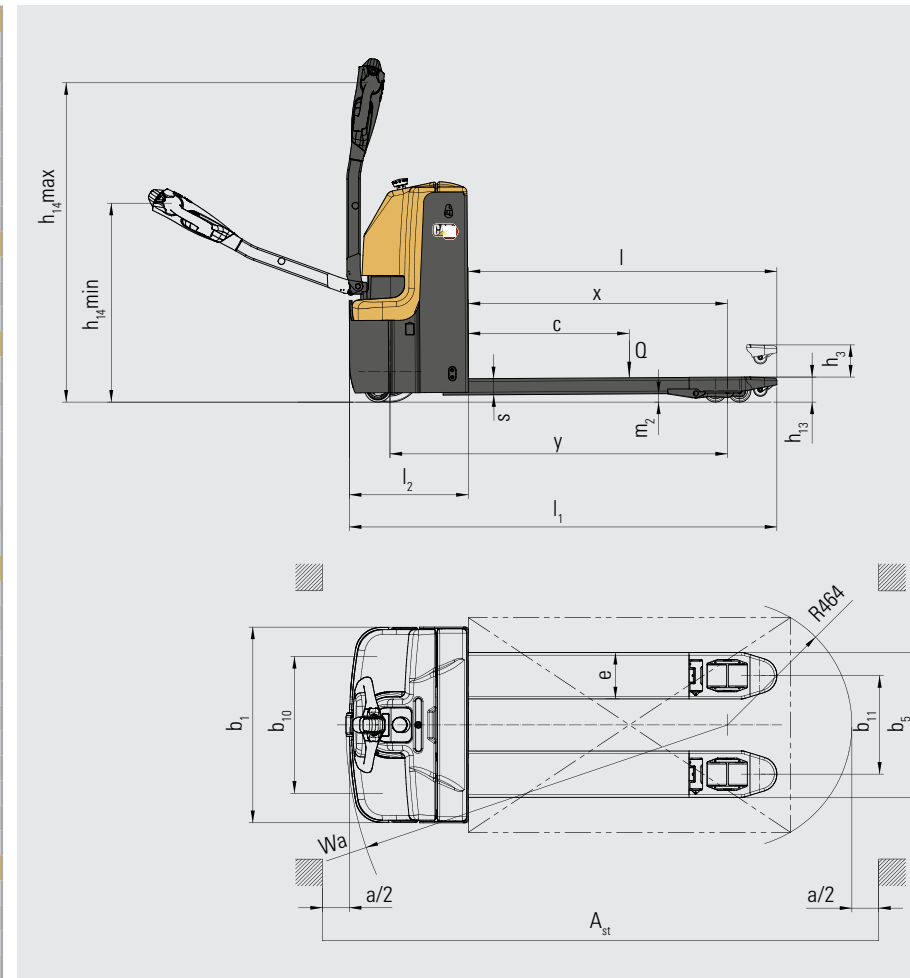

STANDARD EQUIPMENT AND OPTIONS

GENERAL	NPP16Q2L
Drive motor: 1.3kW AC	●
0.8kW pump	●
Curtis controller and display	●
PIN code access and RFID card	●
Forks: 540 x 1150mm	●
24V/100Ah Li-ion battery and 24/40A charger	●
Speed reduction in curves	○
Forks: 685 x 1150mm	○
Load backrest	○
UK plug	○

● Standard ○ Option

CAT LIFT TRUCKS QUALITY – FOR EVEN THE SMALLEST JOBS

Our EQ line warehouse trucks have everything you need for dependable, entry-level materials handling. That includes sturdy construction, simple maintenance, energy-efficient features, robust performance, user-friendly design, and safety. A product line for light applications. If that's what you need to get your job done, the EQ line is your perfect choice.

Compact size and ergonomic tiller-arm control make the truck quick and comfortable in operation. With its small turning radius, it's ideal for work in tight spaces. Lorries, elevators, congested loading docks and narrow aisles are just a few examples. Pallet load handling is smooth and strong, thanks largely to the high-quality forks and modern AC drive motor.

Li-ion battery technology and flexible, convenient charging ensure maximum productive action.

Durable construction and minimal maintenance needs mean low servicing bills. Together with a low price, long service life and economical energy consumption, these factors reduce your total cost of operation (TCO).



LOWER COST OF OWNERSHIP

- High-quality, robust construction – including steel chassis frame – ensures reliable operation over a long lifetime, with minimal servicing and repair needs.
- AC drive motor promises a long service life with low maintenance needs.
- Li-ion batteries give maximum lifespan, efficiency and runtime, with no need for water top-ups or other maintenance.
- Fast plug-in diagnostics, troubleshooting and programming – via an external port – reduce downtime and maintain efficient performance.
- Easy service access – including quick-release cover – saves on time and cost of maintenance.
- Convenient PIN code access and keyless start, supported by RFID tags, prevents unauthorised use and saves time.

UNMATCHED PRODUCTIVITY

- Powerful drive motor technology provides high performance, with strong gradeability, and easily overcomes obstacles and bumps.
- Compact and stable design, with small turning radius, enables fast, safe performance with great manoeuvrability.
- Optional automatic cornering speed reduction avoids loss of stability.
- 24V/100Ah high-capacity battery option gives powerful performance and long runtime between charges.
- Li-ion technology makes continuous operation possible, without battery changes, using fast opportunity charging during short breaks.

SAFETY AND ERGONOMICS

- Ergonomic, spring-loaded, long tiller arm provides a comfortable grip and low-effort operation for maximum control with minimal fatigue or strain.
- Multifunctional tiller head conveniently places controls within easy reach and enables one-handed operation.
- Turtle/creep speed button allows manoeuvring with tiller arm vertical, for safe movement through narrow spaces.
- Li-ion battery chemistry means no risk of hazardous gas or acid leaks.
- Load backrest option enhances stability of pallet and goods.

EQ LINE LI-ION BATTERIES

Our EQ line warehouse trucks come equipped with lithium-ion (Li-ion) battery technology.

A great advantage of Li-ion is that it allows the use of opportunity charging. Instead of exchanging batteries between shifts, you can simply plug into a fast charger during short breaks. Your business will also enjoy the other efficiency, environmental and safety benefits outlined here.



LONGER LIFE

– 3 to 4 times lead-acid lifespan –
reduces overall battery investment



FASTER CHARGING

– enables full charge in as little as
1 hour with the fastest chargers



HIGHER EFFICIENCY

– energy losses during charging and
discharging are up to 30% lower, so
electricity consumption is reduced



NO BATTERY CHANGING

– fast opportunity charging –
15 minutes for several hours of
extra runtime – makes operation
convenient with just one battery and
minimises the need to buy, store and
maintain spares



LONGER RUNTIME

– thanks to more efficient battery
performance and use of opportunity
charges, which can be given at any
time without damaging the battery or
shortening its lifespan



NO DAILY MAINTENANCE

– the battery stays on board the
truck for charging and there is
no need for water top-ups or
electrolyte checks

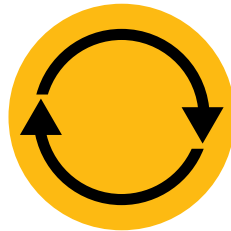

CONSISTENTLY HIGH PERFORMANCE

– with a more constant voltage curve
– maintains truck performance even
as battery charge gets low



INBUILT PROTECTION

– intelligent battery management
system (BMS) automatically
prevents excessive discharge,
charge, voltage and temperature, as
well as virtually eliminating misuse

info@catliftruck.com | www.catliftruck.com

WESC2585(04/26) © 2026 Logisnext Europe B.V. All rights reserved. CAT, CATERPILLAR, LET'S DO THE WORK, and their respective logos "Caterpillar Corporate Yellow", the "Power Edge" and Cat "Modern Hex" trade dress as well as corporate and product identity used herein are trademarks of Caterpillar used under license and may not be used without permission from Caterpillar. Specifications are indicative and may vary depending on operating conditions. Failure to assess all factors may result in performance deviations. All relevant sales support materials and technical expertise of the official distributor must be considered when identifying the best product/solution. Options and technical details may change without notice. Full legal notice and up-to-date product information: www.catliftruck.com.



WATCH
VIDEOS



DOWNLOAD
OUR APP

